

## Stainless Steel

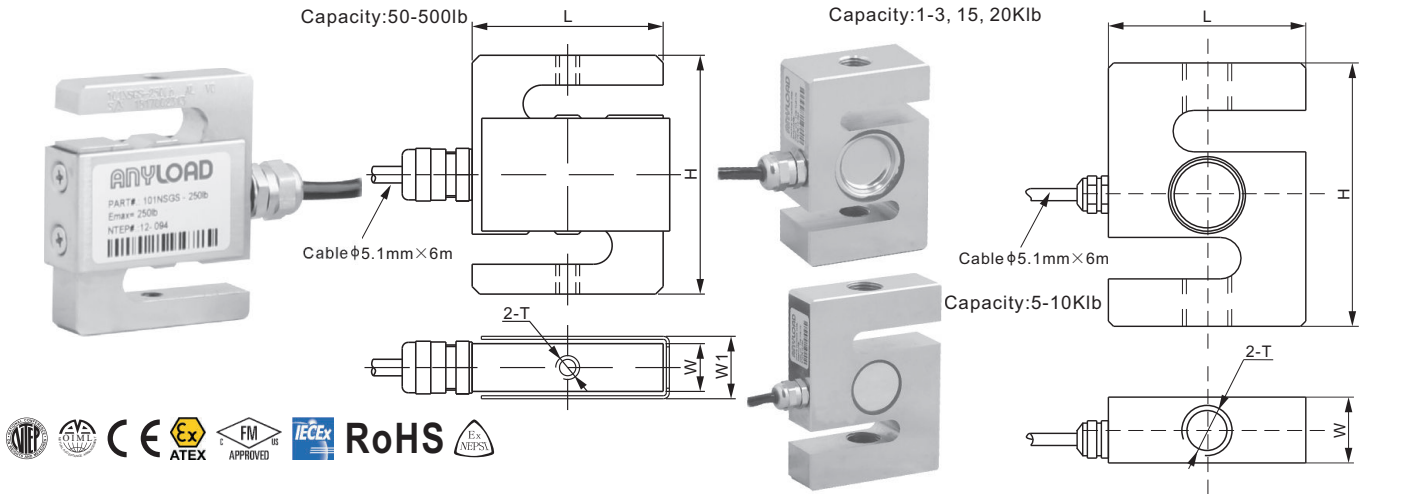

### DIMENSIONS

RATED CAPACITY	H	L	W	W1	T
<b>lb/inches</b>					
50-250	2.50	2.00	0.50	0.65	1/4-28 UNF-2B
500	3.00	2.00	0.75	0.89	1/2-20 UNF-2B
1,000-3,000	3.00	2.00	1.11	-	1/2-20 UNF-2B
5,000; 10,000	4.00	3.00	1.00	-	3/4-16 UNF-2B
15,000	5.50	4.00	1.25	-	1-14 UNS-2B
20,000	7.00	5.00	2.00	-	1 1/4-12 UNF-2B
<b>kg/mm (conversion of above dimensions)</b>					
22.68-113.4	63.5	50.8	12.7	16.6	1/4-28 UNF-2B
226.8	76.2	50.8	19.1	22.6	1/2-20 UNF-2B
453.6-1,360.8	76.2	50.8	28.2	-	1/2-20 UNF-2B
2,268; 4,535.9	101.6	76.2	25.4	-	3/4-16 UNF-2B
6,803.9	139.7	101.6	31.8	-	1-14 UNS-2B
9,071.8	177.8	127.0	50.8	-	1 1/4-12 UNF-2B

### SPECIFICATIONS

<b>Full Scale Output</b>	3.0 mV/V ± 1%	<b>Recommended Excitation</b>	10V (15V Maximum)
<b>Zero Balance</b>	± 0.02 mV/V	<b>Insulation Resistance</b>	>2 [ 50V DC ] GΩ
<b>Non-linearity</b>	< ± 0.017%	<b>Compensated Temperature Range</b>	-10°C to 50°C / 14°F to 122°F
<b>Repeatability</b>	< ± 0.017%	<b>Safe Overload</b>	150% of full scale
<b>Hysteresis Error</b>	< ± 0.017%	<b>Breaking Overload</b>	300% of full scale
<b>Creep in 30 min.</b>	< ± 0.023%	<b>Seal Type / IP Rating</b>	Cap. ≤ 500lb: Environmentally Sealed / IP66
<b>Input Resistance</b>	350Ω ± 7	<b>Cable Color Code</b>	Cap. ≥ 1Klb: Environmentally Sealed / IP67
<b>Output Resistance</b>	350Ω ± 3		Exc+ Red    Exc- Black
<b>Element Material</b>	17-4PH Stainless Steel		Sig+ Green    Sig- White    Shield Bare

### PART NUMBER\*

Rated Capacity	Part No.	Weight (kg) Approx.
50lb	101NSGS-50lb	0.5
100lb	101NSGS-100lb	0.5
250lb	101NSGS-250lb	0.5
500lb	101NSGS-500lb	0.7
1Klb	101NSGS-1Klb	0.8
2Klb	101NSGS-2Klb	0.8
2.5Klb	101NSGS-2.5Klb	0.8
3Klb	101NSGS-3Klb	0.8
5Klb	101NSGS-5Klb	1.3
10Klb	101NSGS-10Klb	1.3
15Klb	101NSGS-15Klb	3.0
20Klb	101NSGS-20Klb	6.8

### INTERCHANGEABLE REFERENCE

Manufacturer	Model
Coti Global	CGSB-SS
Rice Lake	RL20000 SS
Rice Lake	RL20000 ST
Vishay Celtron	STC-SS
Vishay Revere Transducers	9363
Vishay Sensortronics	60050

100lb-500lb: NTEP 1:4 500 Class III, Single Cell;  
 1Klb-20Klb: NTEP 1:5 500 Class III, Single Cell  
 200kg-1.5t: OIML MAA C3, Y=17 000;  
 2t-10t: OIML MAA C4.5, Y=14 000

\* ATEX, FM, IECEx approved versions carry the "-Ex" suffix.