

1. Special Features

- Can be connected with 4 load cells
- Each connection has independent adjustable resistance, excitation trim
- ABS casting

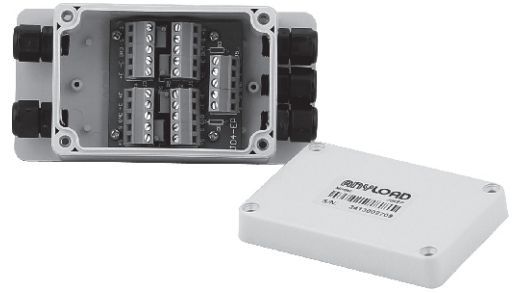

2. Dimensions (in mm; 1mm=0.03937 inches)

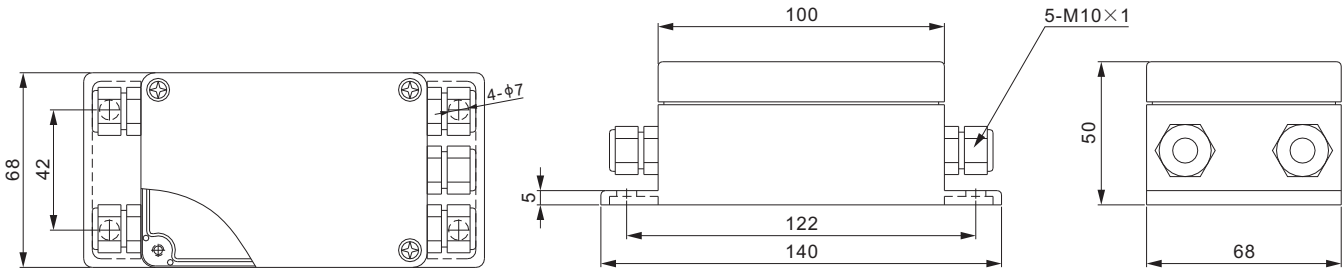

3. Connecting Diagram

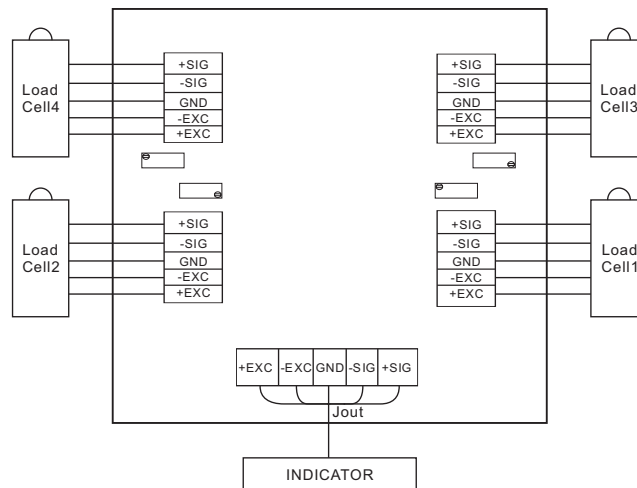

4. Technical Data

Type		J04EP
Trimming		Excitation trim
Weight, approx	kg	0.22
Max. Permissible Voltage	V	18
Materials		ABS
Outline (L*W*H)	mm	140*68*50
Nominal Temperature Range	°C [°F]	-10...+50 [14...122]
Storage Temperature Range	°C [°F]	-20...+60 [-4...140]
Cable Connection for Cable Diameter		Input: M10: 2-6mm, Output: M10: 2-6mm
Protection Class According to IEC529		IP65

5. Application

4 channel signals generated from the load cells which distributed at the corners of the weighing platform, synthesize into one channel signal and send to the weighing indicator after balance adjustment.

6. Trimming Procedure

Trimming is a process of equalizing the output from multiple individual load cells by adjusting each matched potentiometer.

Tools needed: a) A flat head screwdriver which is good for potentiometer adjustment and a Phillips screwdriver which is good for fasten bolts;
b) A 4.5 digits(at least) multi-meter.

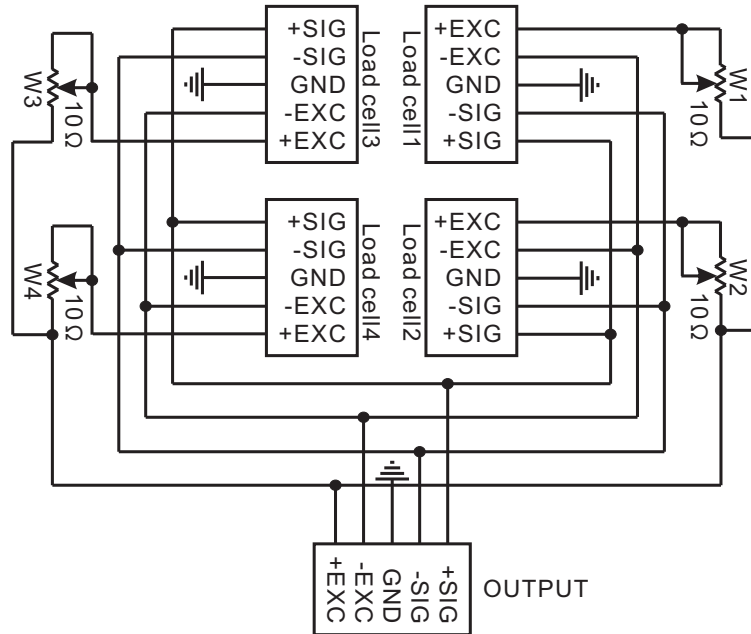

6.1 Trimming connection

Refer to above figure, fix one of the multi-meter test pin to +EXC of OUTPUT port, and fix another pin to +EXC of Load Cell port to read the total resistance of W_i ($i=1,2,3,4$).

6.2 Trimming Steps

- 1) Each potentiometer was factory setting to 5ohms with counterclockwise up to Max. 10ohms and clockwise down to 0ohms. Double check each potentiometer resistance, if it's not 5ohms, please trim it to 5ohms to make future trimming easy.
- 2) Connect each load cell cable to the matched terminal of J04EP through M10 as figure shown above, connect indicator with a cable through M10 with J04EP properly as well. Set the indicator to Zero, then place test weights over each load cell (each corner) and on the center point in turn. For a four load cell scale, it's recommended using a weight of 25% of full scale capacity.
- 3) Record the value displayed on the indicator after test weight is placed in turn on each corner and center. Select the lowest corner value comparing with center value, adjust the potentiometer of the corner by clockwise turn to increase the value of this corner, or select the greatest value comparing with center value, then trim the potentiometer of the corner by counterclockwise turn to decrease the value of this corner.
- 4) Replace the same test weight over each cell and center in turn. Adjust the potentiometers to trim each load cell up or down to equal the value of each corner to the center. Check all cells again for repeatability, repeat steps 2 and 3 if necessary until all the value is within the required range.
- 5) Place the box cover on and tighten the cover screws, make sure the gasket is compressed equally in all locations.