

### 1. Special Features

- Can be connected with 8 single cells
- Each connection has independent adjustable resistance, signal trim
- Stainless steel SS304
- Unique patented design, easy for installation, never-lose bolts

### 2. Dimensions (in mm; 1mm=0.03937 inches)

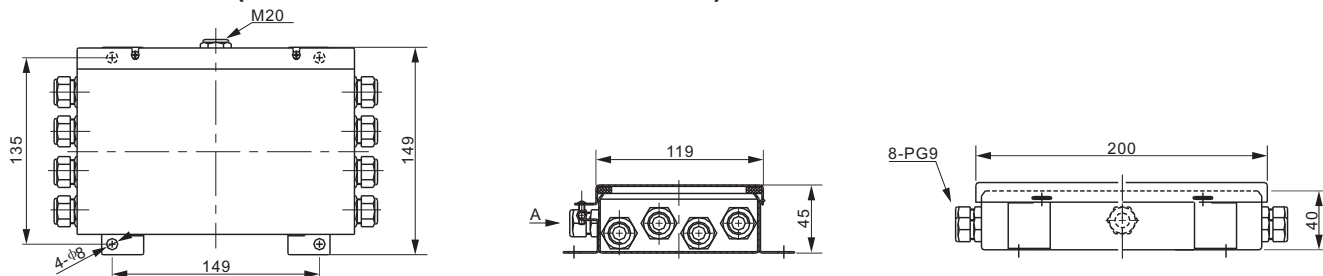

### 3. Connection Diagram

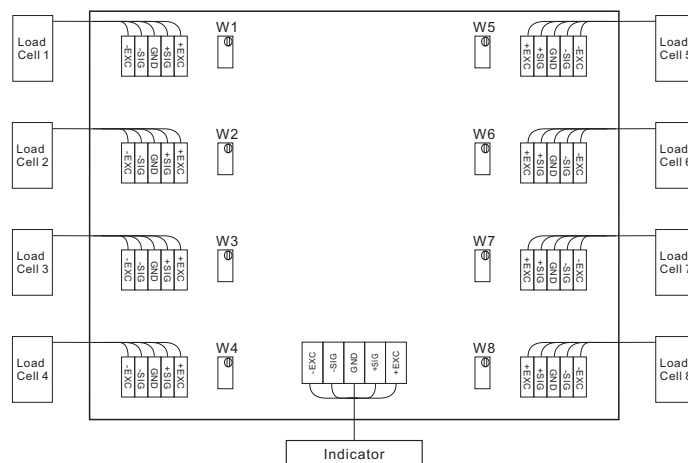

### 4. Technical Data

Type		J08SS-I
Trimming		Signal trim
Weight, approx	kg	0.9
Max. Permissible Voltage	V	18
Materials		Stainless steel SS304
Outline (L*W*H)		mm 200*149*45
Nominal Temperature Range		°C [°F] -10...+50 [14...122]
Storage Temperature Range		-20...+60 [-4...140]
Cable Connection for Cable Diameter		Input: PG9: 4-8mm, Output: M20: 6-12mm
Protection Class According to IEC529		IP65

### 5. Application

8 channel signals generated from the load cells which distributed at the corners of the weighing platform, synthesize into one channel signal and send to the weighing indicator after balance adjustment.

### 6. Trimming Procedure

Trimming is a process of equalizing the output from multiple individual load cells by adjusting each matched potentiometer.

Tools needed: a) A flat head screwdriver which is good for potentiometer adjustment and a Phillips screwdriver which is good for fasten bolts;

b) A 4.5 digits(at least) multi-meter.

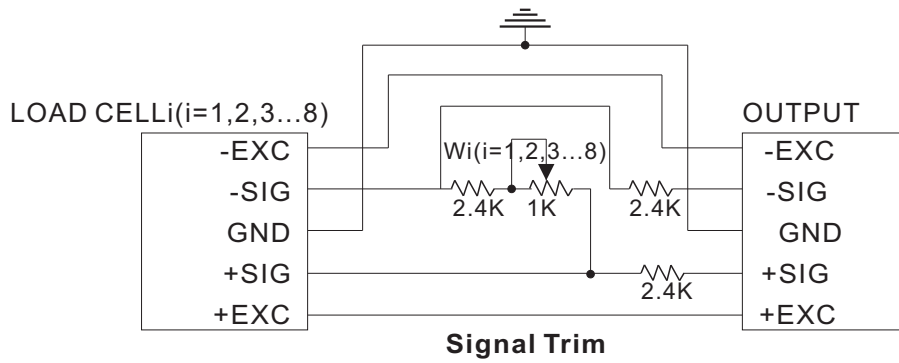

**6.1 Trimming Connection**

Please refer to above figure, fix one of the multi-meter test pin to +SIG of Load Cell port, and fix another one to -SIG of Load Cell port, to read the total resistance of  $W_i(i=1,2,3...8)$  in series with a 2.4K ohms resistor.

**6.2 Trimming Steps:**

- 1) Connect each load cell cable to the matched terminal of J08SS-I through PG9 as "Connection Diagram" shown above, connect indicator with a cable through M20 with J08SS-I properly as well. Set the indicator to Zero, then place test weights over each load cell (each corner) and on the center point in turn. For an eight load cell scale, it's recommended using a weight of 25% of full scale capacity.
- 2) Record the value displayed on the indicator after test weight is placed in turn on each corner and center. Select the lowest corner value comparing with center value, adjust the potentiometer of the corner by clockwise turn to increase the value of this corner, or select the greatest value comparing with center value, then trim the potentiometer of the corner by counterclockwise turn to decrease the value of this corner.
- 3) Replace the same test weight over each cell and center in turn. Adjust the potentiometers to trim each load cell up or down to equal the value of each corner to the center. Check all cells again for repeatability repeat steps 1 and 2 if necessary until all the value is within the required range.
- 4) Place the box cover on and tighten the cover screws, make sure the gasket is compressed equally in all locations.