

Features:

- 1-piece casting (the grip handle & body in one piece), safe and solid
- Embedded adjusting cavity for sealing, reliable and convenient
- Nominal value marked on the surface
- Flat top for easy and secure stacking, sloped-sloth space to prevent rainwater and dust accumulation
- Wide slot space to fit most fork lifts
- Smooth surface, durable coat of paint to protect from weather
- Embossed marking, easy to clean and maintain

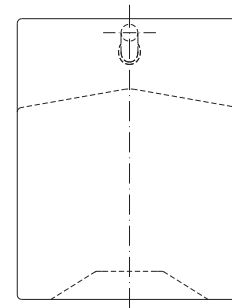
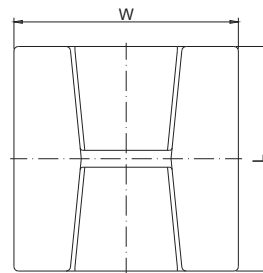
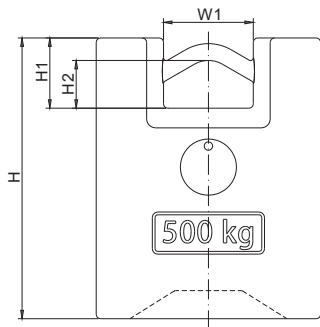

Top view

Side view

DIMENSIONS

RATED CAPACITY	H	H1	H2	L	W	W1
kg/mm						
500	500	125	85	400	400	160
lb/inches (conversion of above dimensions)						
1102.3	19.7	4.9	3.3	15.7	15.7	6.3

PART NUMBER

Rated Capacity	Class	Part No.
500kg.....	OIML M1.....	TWCM1-500kg-MC